

# RELAX

Guy Bonneville

# BLAM

DRIVEN BY PASSION

## R10 DB

subwoofer

- Hi efficiency 270 mm (10") subwoofer
- Max. power 800 W / Nominal Power 400 W

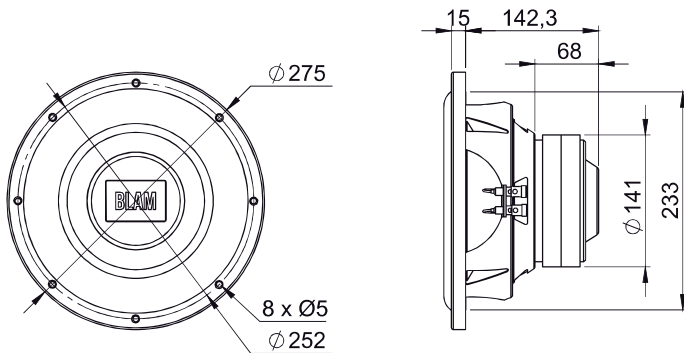

### TECHNICAL SPECIFICATIONS

Component	Subwoofer	
Max power	800 W	
Nominal power	400 W	
Impedance	2 x 2 Ω	
Freq. Response	33 Hz - 500 KHz	
Sensitivity (2,83V/1m)	94 dB	
Magnet	Ferrite	
Magnet size Ø x h	140 x 40 mm	5,512" x 1,575"
Total driver displacement	1,1100 l	0,039 cf
Weight of one component	5,4 kg	11,905 lb
Voice coil Ø	60 mm	2,362"
Voice coil height	30 mm	1,181"
Cone	Rigid treated cellulose pulp	

### THIELE-SMALL PARAMETERS

effective Ø (d)	220 mm
Sd	380,13 cm <sup>2</sup>
Xmax	11 mm
Re	1 Ω
Fs	33,59 Hz
Le	271,05 µH @ 1 kHz
Le	853,69 µH @ 10 kHz
Vas	26,02 L
Mms	175,16 g
Cms	0,000128 m/N
BL	9,06 Tm
Qts	0,41
Qes	0,45
Qms	5,65
SPL (dB/W/m)	85,4 dB

### FREQUENCY RESPONSE / IMPEDANCE

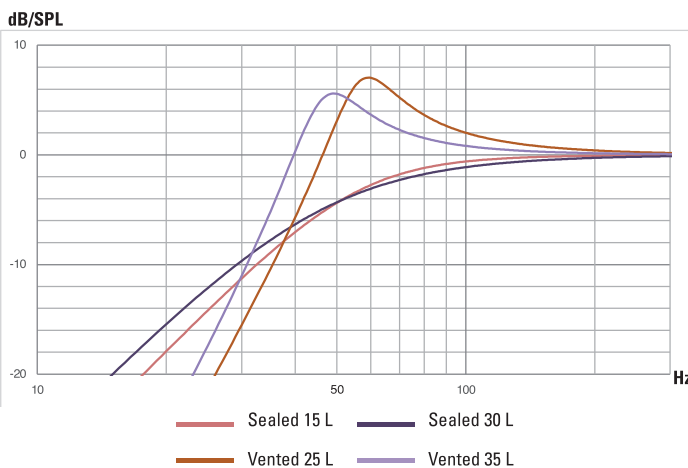

### SEALED

Internal volume Vb	Resonance frequency	Qts	Fb	F-3dB	Boost
15 L	56 Hz	0,678	-	58 Hz	0,0 dB
30 L	46 Hz	0,56	-	61 Hz	0,0 dB

### VENTED

Internal volume Vb	Internal ø port	Length port	Fb	F-3dB	Boost
25 L	10 cm	26 cm	53 Hz	44 Hz	7 dB at 59 Hz
35 L	10 cm	26 cm	40 Hz	38 Hz	5,6 dB at 51 Hz

contact@blam-audio.fr  
www.facebook.com/blamaudio  
www.blam-audio.fr